

# 7200 PLUS AND 7400 PLUS CONTROLLERS

*MULTICHANNEL GAS MONITORING SYSTEM*



## THE SCOTT 7200 PLUS AND 7400 PLUS CONTROLLERS

are designed to provide simultaneous display and alarm functions for up to four monitored variables. A graphic LCD displays monitored data as bar graphs and engineering units. Three adjustable alarm levels are provided per channel. Relay outputs allow control of beacons, horns and other alarm events.

The controllers are easy to configure and user friendly. Measurement ranges in engineering units, adjustable alarm set-points, optional serial interfaces and many other features offer flexibility to meet most demanding applications.

The controllers utilize NEMA 4X rated enclosures and are CSA certified to CSA C22.2 No. 152 for combustible detection and Class I, Division 2, Groups A, B, C and D hazardous locations. An optional RS-485 MODBUS® slave port allows up to 128 controllers to be multidropped onto a single data highway for interrogation by another MODBUS master.

Other 7200 Plus options include six 5 amp SPDT discrete alarm relays per channel, 4 to 20 mA outputs and light stacks. Nonvolatile memory retains all configuration data indefinitely.

### Common Markets Include:

- Petrochemical Oil and Gas
- Food and Beverage
- Pulp and Paper
- Water and Wastewater Treatment

## PRODUCT FEATURES

- Centralized Graphic Display and Alarm Controller
- Seamless Upgrade for Current Loop and Direct Cat Bead Detectors
- MODBUS Interfacing and Output Relay Options for Any Environment
- Compatibility with Scott's Full Array of Gas Detection Transmitters and Detectors
- Hazardous Location Approval for Class I, Division 2 Applications



# 7200 PLUS AND 7400 PLUS CONTROLLERS

## MULTICHANNEL GAS MONITORING SYSTEM

### SYSTEM SPECIFICATIONS

**Inputs:** Sensor input PCBs are available for combustible sensor and 4 to 20 mA. All versions may be configured for 4 to 20 mA inputs.

**Analog Outputs:** 10 bit 4 to 20 mA output. Max load 800 ohms with nominal 24 VDC power supply (Optional)

**Common Alarm Relays:** (Standard) Two 5 amp 30 VDC or 250 VAC resistive Form C

**Discrete Alarm Relays:** (Optional) Six 5 amp 30 VDC or 250 VAC resistive Form C

**Serial Port:** (Optional) Master and slave RS-485 port equipped with Tx/Rx LEDs. Protocol = MODBUS RTU. 10-BaseT Ethernet with MODBUS TCP protocol

**Display:** 128 x 64 pixel graphic LCD with backlight displays bar graphs, 30-minute trends and engineering units. Six discrete LEDs indicate alarm status for three alarms per channel

**Ambient Temperature Range:** -25°C to 50°C

**Humidity:** 0 to 90% R.H. non-condensing

**Power Supply:** 100 to 240 VAC or 24 VDC are standard primary power supplies. AC power source generates 24 VDC at 8 watts auxiliary power.

**Housing Options:** NEMA 4X wall mount CSA certified for Class I, Division 2, Groups A, B, C, D  
NEMA 7 explosion-proof wall mount for Division 1 areas

### APPROVALS:

UL 1604 C22.2 No 213 (Division 2, Groups A, B, C, D); EN55011 and EN61000 (CE Mark).  
CSA File # = 219995 and may be seen at: [www.CSA-International.org](http://www.CSA-International.org).

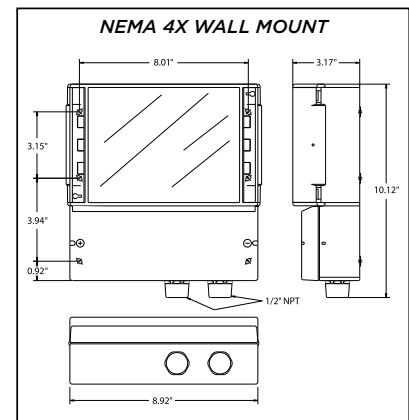
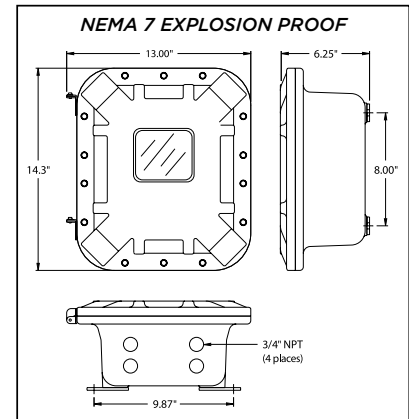

### Complete 7200 Plus Instruments

Part Number	Description
093-0427	7200 Plus 2 Channel 4 to 20 mA Input Board NEMA 4X Enclosure and Audible Alarm
093-0428	7200 Plus 2 Channel Direct Cat Bead Input Board, NEMA 4X Enclosure and Audible Alarm
093-0429	7200 Plus 2 Channel 4 to 20 mA Input Board in a NEMA 7 Enclosure
093-0430	7200 Plus 2 Channel Direct Catalytic Bead Board Input Board in a NEMA 7 Enclosure

### Complete 7400 Plus Controller

Part Number	Description
093-0456	NEMA 4X Enclosure 4 Channel Direct Cat Bead Input Audible Alarm
093-0458	NEMA 4X Enclosure 4 Channel 4 to 20 mA Input Audible Alarm
093-0460	NEMA 7 4 Enclosure Channel Direct Cat Bead Input
093-0462	NEMA 7 4 Enclosure Channel 4 to 20 mA Input

Note: Transmitter power requirements must be <12 watts, an additional power supply is available for greater power demand.

© 2011 Scott Safety. SCOTT, the SCOTT SAFETY Logo and Scott Health and Safety are registered and/or unregistered marks of Scott Technologies, Inc. or its affiliates.  
Monroe Corporate Center • P.O. Box 569 • Monroe, NC 28111  
Telephone: 800.247.7257 • Facsimile: 704.291.8330  
[www.scottsafety.com](http://www.scottsafety.com) • [sh-sale@tycoint.com](mailto:sh-sale@tycoint.com)

MODBUS is a trademark of Schneider Electric.

H/S 6660B 05/11 ISO 9001 Registered. All rights reserved.