

FCI ST98 Series Thermal Mass Flow Meters

Gas Flow Measurement Solutions
for Process and Plant Applications

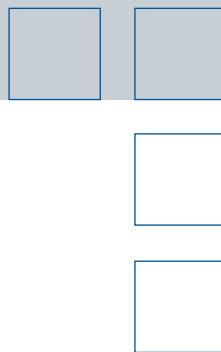

- Chemical
- Wastewater Treatment, Landfills
- Refineries
- Oil & Gas
- Mining
- Metals
- Manufacturing
- Cement, Stone, Brick, Glass
- Power Utilities
- Pulp & Paper
- Food & Beverage
- And more...

FCI ST98 SERIES

FCI FLUID COMPONENTS
INTERNATIONAL LLC

ST98 Series Features

- Air and Gas Direct Mass Flow Measuring
- Flow Rate, Total Flow, and Temperature Display
- No Moving Parts, Lowest Maintenance
- Line Sizes 1" to 42" [25 to 1066 mm]
- Precision Calibrated
- Fluid Temperatures to 850 °F [454 °C]
- Rugged, All-Metal Agency-Certified Enclosures
- Integral and Remote Electronics Versions
- Comprehensive Approvals for Hazardous Locations
- RS232C, HART® and PROFIBUS® Communications
- 110 Year MTBF



Model ST98 is an insertion flow meter for pipe sizes from 2 1/2" to 42" [64 to 1066 mm]. Typical calibration range is from 0.75 to 600 SFPS [0.21 to 172 NMPS].¹



Model ST98L is an in-line flow meter for use in line sizes 1", 1 1/2" and 2" [DN25, DN40, and DN50]. Typical calibration range is from 0.006 SCFM to 1850 SCFM [0.01 NCMH to 3140 NCMH].¹

The ST98 Air / Gas Mass Flow Meter Solution

ST98 flow meters combine proprietary equal mass thermal dispersion flow sensing elements, precision electronics, and exacting fluid calibrations, all packaged within rugged, industrial enclosures. The ST98 Series delivers a superior air/gas flow measurement solution that continuously meets performance specifications in the most demanding process and plant applications with virtually no scheduled maintenance.

ST98 flow meters feature FCI's patented no-moving parts flow element design that provides direct mass flow measurement with just a single process penetration. This saves you space and eliminates unnecessary installation, expense, and performance degradation associated with separate temperature and pressure sensors, and density calculation devices needed with inferred mass flow techniques. With no moving parts to plug or foul, ST98's deliver extensive cost savings over alternative high maintenance technologies. The result is an accurate and highly repeatable mass flow measurement at the lowest total installed cost. In today's complex process control schemes, the ST98 Series provides accurate gas flow measurements essential for process consistency, quality and safe plant operation.

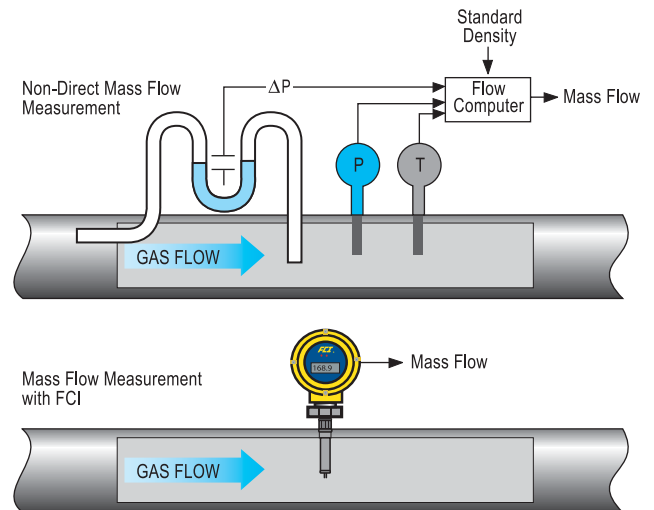

FCI's ST98 Series features an accuracy of ±1% of reading, 0.5% of full scale and repeatability of ±0.5% of reading. The turndown ratio is factory preset to your application from a minimum of 10:1 to a maximum of 100:1 and is field adjustable within the calibrated range. ST98 flow meters are offered in a wide range of packaging options, mounting and installation options that ensure configuration matched to your exact application conditions. From compressed air to hydrocarbon gases, single gases to bio-gas mixtures, ST98 flow meters are at work improving processes throughout the world.

¹ At standard conditions of 70 °F and 14.7 psia [0 °C and 1.013,25 mBara for metric normal conditions]. Actual calibration range depends on actual fluid and conditions.

Sensors Optimized to Meet the Application

To match your flow application conditions, the ST98 and ST98L are both offered in a choice of two element designs. ST98 choices are –FP and –S. ST98L choices are –F and –S.

Select the –FP and –F style element for applications in dry, clean air/gases with fluid temperatures up to 850 °F [454 °C]. The –FP and –F designs incorporate FCI's exclusive equal mass sensor in smaller diameter thermo-wells for faster response time and improved repeatability in processes with dynamic temperature swings. The –FP also features a protective shroud.

Select the –S style element when your application involves dirty or erosive fluids, high moisture content gas or a pulsating flow. The –S element features more robust, thicker wall thermo-wells and an un-shrouded equal mass sensor element that provides a noise-filtered response, extended erosion resistance, and easier cleaning. In wet/dirty gas applications such as digester, landfill, bio-gases, wet compressed air, or with erosive particulates in the gas, the –S sensor element is often the optimal choice.

ST98 and ST98L models feature an all-welded element to ensure maximum strength, durability and leak proofing. Elements are available in 316L stainless steel or, for applications in highly corrosive fluids, Hastelloy-C materials of construction.



	Sensor Type	Material of Construction	All Welded	Standard Temperature Range to 350 °F [177 °C]	High Temperature Range to 500 °F [260 °C]	Ultra-High Temperature Range to 850 °F [454 °C]
ST98 Insertion	–FP	316L Stainless Steel	Yes	✓		ST98 HT (<i>new</i>) ✓
	–FP	Hastelloy-C	Yes	✓		ST98 HT (<i>new</i>) ✓
	–S	316L Stainless Steel	Yes	✓	✓	ST98 HT ✓
	–S	Hastelloy-C	Yes	✓	✓	ST98 HT ✓

ST98L In-Line	–F	316L Stainless Steel	Yes	✓		
	–F	Hastelloy-C	Yes	✓		
	–S	316L Stainless Steel	Yes	✓		
	–S	Hastelloy-C	Yes	✓		

Find your gas here?

FCI has provided thermal mass flow meter solutions for all of these and more...

Acetaldehyde	Ethyl Acrylate	Krypton	Propadiene
Acetic Acid	Ethyl Alcohol	Landfill Gas	Propane
Acetone	Ethyl Amine	(CH ₄ + CO ₂)	Propanol
Acetonitrile	Ethyl Benzene	M-Cresol	Propyl Chloride
Acetyl Chloride	Ethyl Bromide	Mercury	Propylene
Acetylene	Ethyl Chloride	Methane	Propylene Oxide
Air	Ethyl Fluoride	Methanol	Propyne
Allyl Chloride	Ethyl Mercaptan	Methyl Acetate	P-Xylene
Ammonia	Ethylene	Methyl Alcohol	R-11
Aniline	Ethylene	Methyl Amine	R-112
Argon	Dichloride	Methyl Butane	R-113
Benzene	Ethylene Oxide	Methyl Fluoride	R-114
Bio-Gas	Flare Gas	Methyl Formate	R-114B2
(CH ₄ + CO ₂)	Fluorine	Methyl Hexane	R-115
Boron Trifluoride	Fluorobenzene	Methyl Hydrazine	R-116
Bromine	Fluoriform	Methyl	R-12
Bromobenzene	Freon-11	Mercaptan	R-13
Butadiene	Freon-12	Methyl Octane	R-13B1
Butene	Freon-13	Methyl Pentane	R-14
Butylene Oxide	Freon-14	Methylal	R-142B
Butyne	Freon-21	Methylene	R-152A
Carbon Dioxide	Freon-22	Chloride	R-21
Carbon Disulfide	Freon-23	Morpholine	R-216
Carbon Monoxide	Furan	M-Xylene	R-22
Carbon	Halon	Naphthalene	R-23
Tetrachloride	Helium	Natural Gas	R-500
Carbonyl Sulfide	Heptene	N-Butane	R-502
Chlorine	Hexanol	N-Butane	R-503
Chlorobenzene	Hexene	N-Butanol	R-504
Chloroethane	Hydrazine	N-Butyl Alcohol	Radon
Chloroform	Hydrogen	N-Decane	R-C318
Chloromethane	Hydrogen	N-Dodecane	Saturated Steam
Chloroprene	Bromide	Neon	Silane
Cis-2-Butene	Hydrogen	Neopentane	Silicon
Cis-2-Hexene	Chloride	N-Heptane	Tetrachloride
Cumene	Hydrogen	N-Hexane	Styrene
Cyanogen	Cyanide	Nitric Oxide	Sulfur Dioxide
Cyclobutane	Hydrogen	Nitrogen	Sulfur
Cyclohexane	Deuteride	Nitrogen Dioxide	Hexafluoride
Cyclooctane	Hydrogen	Nitromethane	Sulfur Trioxide
Cyclopentane	Fluoride	Nitrous Oxide	Superheated
Cyclopropane	Hydrogen Iodide	N-Nonane	Thiophene
Decene	Hydrogen	N-Octane	Titanium
Deuterium	Peroxide	Nonene	Tetrachloride
Deuterium Oxide	Hydrogen Sulfide	N-Pentane	Toluene
Diethyl Amine	Iodine	N-Propanol	Trans-2-Butene
Diethyl Ether	Isobutane	N-Propyl Alcohol	Trimethyl Amine
Diethyl Ketone	Isobutene	N-Propyl Amine	Triptane
Digester Gas	Isobutyl Alcohol	N-Undecane	Uranium
(CH ₄ +CO ₂)	Isoheptane	Octene	Hexafluoride
Dimethyl Ether	Isohexane	Oxygen	Vinyl Acetate
Dimethyl	Isooctane	O-Xylene	Vinyl Chloride
Propane	Isopentane	Ozone	Vinyl Fluoride
Dimethyl Sulfide	Isoprene	Pentanol	Vinyl Formate
Ethane	Isopropyl Alcohol	Phenol	Water Vapor
Ethanol	Isopropyl Amine	Phosgene	
Ethyl Acetate	Ketene		

Robust, Rugged Electronics and Transmitter

ST98 Series transmitters feature robust, microprocessor-based electronics that undergo rigorous testing and quality assurance checks to ensure continuous, reliable long-term operation in the most demanding installations. The electronics feature FCI's exclusive, multi-poly curve fit linearization technique to achieve maximum flow measurement accuracy and repeatability. All gas calibration data specifics for your meter and your application are stored in non-volatile memory and always retained in the event of a power loss.

All wiring terminal blocks are easily and safely accessed through the ST98 enclosure's front door or via the removable dual-covers of the explosion-proof transmitter. The instrument's universal power supply accepts AC (85 to 260 volts) or 24 Vdc. The transmitter's analog output is field selectable as 4-20 mA, 0-5 Vdc, or 0-10 Vdc. An optional digital, 2 line-by-16 character LCD is available to display flow, temperature and total flow.

Digital Communications

ST98 Series models include a serial RS232C I/O port. Instrument configuration and comprehensive diagnostics are performed via simple connection to a portable PC via hyperterminal mode, or via a FCI Model FC88 portable programmer. Actual



measurements, including flow rate, total flow, temperature values, and diagnostics are continuously accessible from the serial output. The industry standard HART and PROFIBUS digital communications protocols are also an available option.



- HART Field Communications Protocol** For connection in HART networks, the ST98 flow transmitter supports two-way communications for easy access to measured process data, diagnostics, calibration and configuration information. Both flow and temperature data are available as PV1 and PV2 within the HART Protocol. FCI's HART manufacturer ID is 0000A6 and the ST98 device type is 0078. Device description (DD) files are installed and downloadable from the HART web site.
- PROFIBUS Process Field Bus** ST98's PROFIBUS interface supports connection in a PROFIBUS network as a –DP device. The communications protocol is fully Profile 3 compatible. In addition, FCI optionally offers single instrument and enterprise level DTM software packages to facilitate and reduce the costs of integrating ST98 into the PROFIBUS network. ST98's PROFIBUS has been certified by the PROFIBUS organization, certification number Z01212.

ST98 Insertion

Hazardous Locations

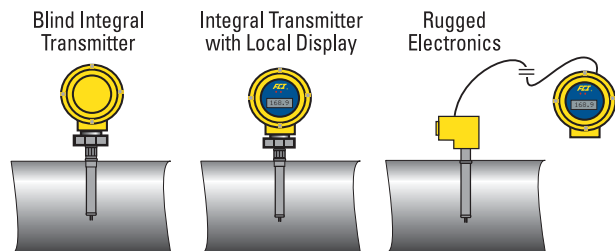

Non-hazardous Locations

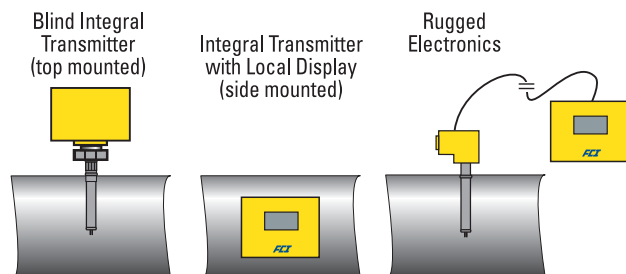

ST98L In-Line

Hazardous Locations

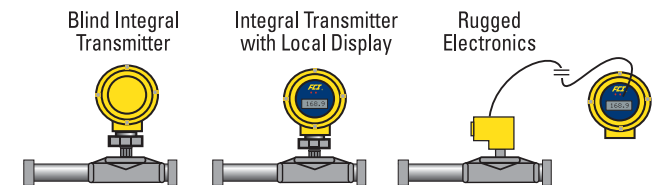

Non-hazardous Locations

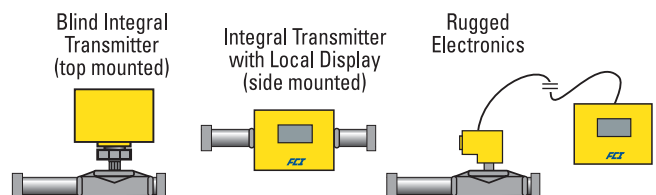



Rugged Packaging for Long Service Life and Installation Choices to Match Your Application

ST98 flow meters are offered in several enclosure configurations to ensure application reliability, readability of the digital display, ease of installation and accessibility. These include a weatherproof, carbon steel NEMA/CSA Type 4 [IP66] rated enclosure, an aluminum NEMA/CSA Type 4X [IP66] rated enclosure, or an aluminum explosion-proof enclosure for hazardous locations. Agency approvals include FM, CSA, ATEX, GOST/RTN, IEC, CPA, and NEPSI. Any of the transmitter enclosure choices can be ordered integrally mounted with the sensor probe or for remote mounting up to 1000 feet (350m) away. Hazardous location approvals meet Class I & II, Div.1 & 2, Groups B, C, D, E, F & G; and per ATEX/IECEX II2 GD Exd IIC T4.

Process Connection Choices for Installation Ease

Standard process connections for the ST98's insertion flow element are a 3/4 or 1 inch male NPT stain-less steel compression fitting with either an adjustable teflon ferrule, rated to 150 psig [10 bar(g)] and 200 °F [93 °C], or a stainless steel ferrule, rated to 250 psig [17 bar(g)] and 500 °F [260 °C]. Optionally available are ANSI or DIN flanges, and retractable packing glands with 1 1/4 inch NPT or flanged connections. The ST98 insertion flow meter is offered in three standard element lengths of 6, 12, or 21 inches [152, 305 or 533 mm], which are field adjustable for final insertion depth to match your application. Longer and fixed insertion lengths, and all-welded process connections are also available upon request. High temperature service model ST98HT is available as a 1 inch male NPT or flanged in fixed insertion lengths up to 60 inches [1524 mm]. Adjustable insertion length requires retractable packing gland configuration.

For the ST98L in-line model, the standard process connections are male or female NPT and ANSI or DIN flanges. The flow tube or pipe length is 9-times its nominal diameter (e.g. a 1 inch pipe model will have a 9 inch long flow tube). Additionally, ST98L may be supplied with built-in Vortab® flow conditioners to reduce straight-run requirements and eliminate swirl and distorted flow profiles.

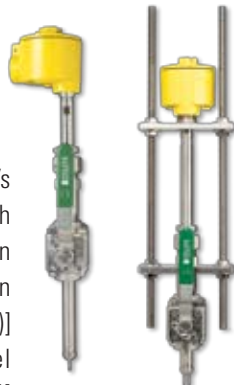

**Packing Gland/
Ball Valves**

FCI Calibration Ensures Installed Accuracy

The ST98 Series is tested and calibrated to rigorous standards to ensure you get the instrument that does the job you specified. To design and produce the highest quality flow instrumentation, FCI operates a world-class NIST traceable flow calibration laboratory certified to meet such stringent standards as MIL-STD 45662A and ANSI/NCSL Z-540.

For most gases, FCI ST98 thermal dispersion flow meters are calibrated using the actual gas as well as the actual temperature and process conditions matching your application. Other suppliers are limited to air calibration with un-validated theoretical equivalencies for gases. FCI has demonstrated this procedure to be inferior and subject to installed errors well outside published specifications. For most other suppliers to perform actual gas calibrations equal to FCI, their flow meter must be sent to an outside laboratory resulting in extra costs and shipping delays to you.

FCI's calibration results in a flow meter you can install with total confidence and assurance that it meets your application needs.

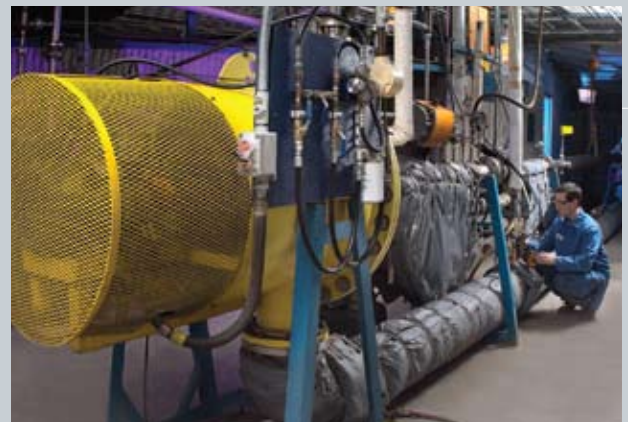

More than 16 precision flow stands to match fluids, process conditions, flow rates and line sizes specified in your application.

ST98 Special Configurations

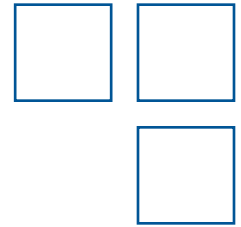

ST98HP - High and Ultra High Purity Applications

For gas applications in pharmaceutical, biotech, food, beverage, semiconductor, or other industries where high purity finishes are required, the model ST98HP is the solution. The ST98HP provides all of the standard features and options of the ST98, combined with electropolish finishes and sanitary process connections. ST98HP is available for line sizes 3/4 inch through 4 inches. The ST98HP is offered in two versions:

- **High Purity** 15Ra finish with a sanitary flange mated to a 316L in-line flow tube. The flow tube can be specified for either butt weld or sanitary flanged process connections.
- **Ultra High Purity** 10Ra finish with a VCR connector mated to a 316L in-line flow tube. The flow tube can be specified for either butt weld or sanitary flanged process connections.



ST98HP is engineered for High Purity applications.



The ST98HP for Ultra High Purity applications has a 10Ra finish.

ST98B - Compressed Air / Air / Nitrogen

Specifically for applications in compressed air, air, or nitrogen, FCI manufactures the ST98B models as standardized configurations of the ST98. The pre-configured and calibrated ST98B is easy to order and stocked for quick delivery.

Model ST98B-CA, for compressed air, is calibrated for a range of 6 to 600 SFPS [1.8 to 183 NMPS]. Model ST98B-AN, for air or nitrogen, is calibrated for 1.25 to 125 SFPS [0.4 to 38 NMPS].

The insertion element has a 3/4 inch diameter (with -FP element) and is offered in two U-lengths; 6 inch [152 mm] and 12 inch [395mm] with male NPT compression fitting and Teflon ferrule for field adjustment to the final insertion depth. The flow meter's transmitter housing is the NEMA 4 [IP66] carbon steel box, and can be ordered as a blind unit or with LCD digital display, in an integral or remote configuration. All other specifications of the ST98 insertion are standard.



Standardized ST98B models are pre-configured and calibrated for compressed air / air or nitrogen.

ST98 Special Treatments, Options and Accessories

Fluid Components International is committed to providing solutions for even the toughest application challenges. FCI has engineered a variety of options and accessories for ST98 models to perform in extraordinary conditions – just a few examples are shown here. Contact FCI with any special needs or for engineered solutions to your specific application.

- **Vortab Flow Conditioners** For plant conditions with limited piping straight-run or significant flow disturbances, FCI ensures accurate and repeatable measurements using Vortab flow conditioners. The patented, proven Vortab technology is widely recommended by industry experts to be the single most effective solution for flow conditioning and flow straightening. FCI is the only thermal dispersion flow technology provider authorized to provide Vortab flow conditioners with its products.



Vortab® Flow Conditioners ensure accurate and repeatable flow performance.

- **Sun and Wind Enclosure Shades** In outdoor installations with constant heat, glaring sun or blowing sand, special sun shades provide additional protection to ensure reliability and operations of the transmitter electronics and the LCD digital display when used with remote enclosures.



A sun and wind shade will help protect the remote transmitter.

- **Element Coatings and Materials** For service in highly corrosive gases or with erosive particulates, FCI can provide special coatings and wetted materials to protect the element and provide longer service life. Examples include Kynar, Tantalum, and Chromium Carbide.



Protective coatings are available for highly corrosive and erosive environments.

ST98 Series Features

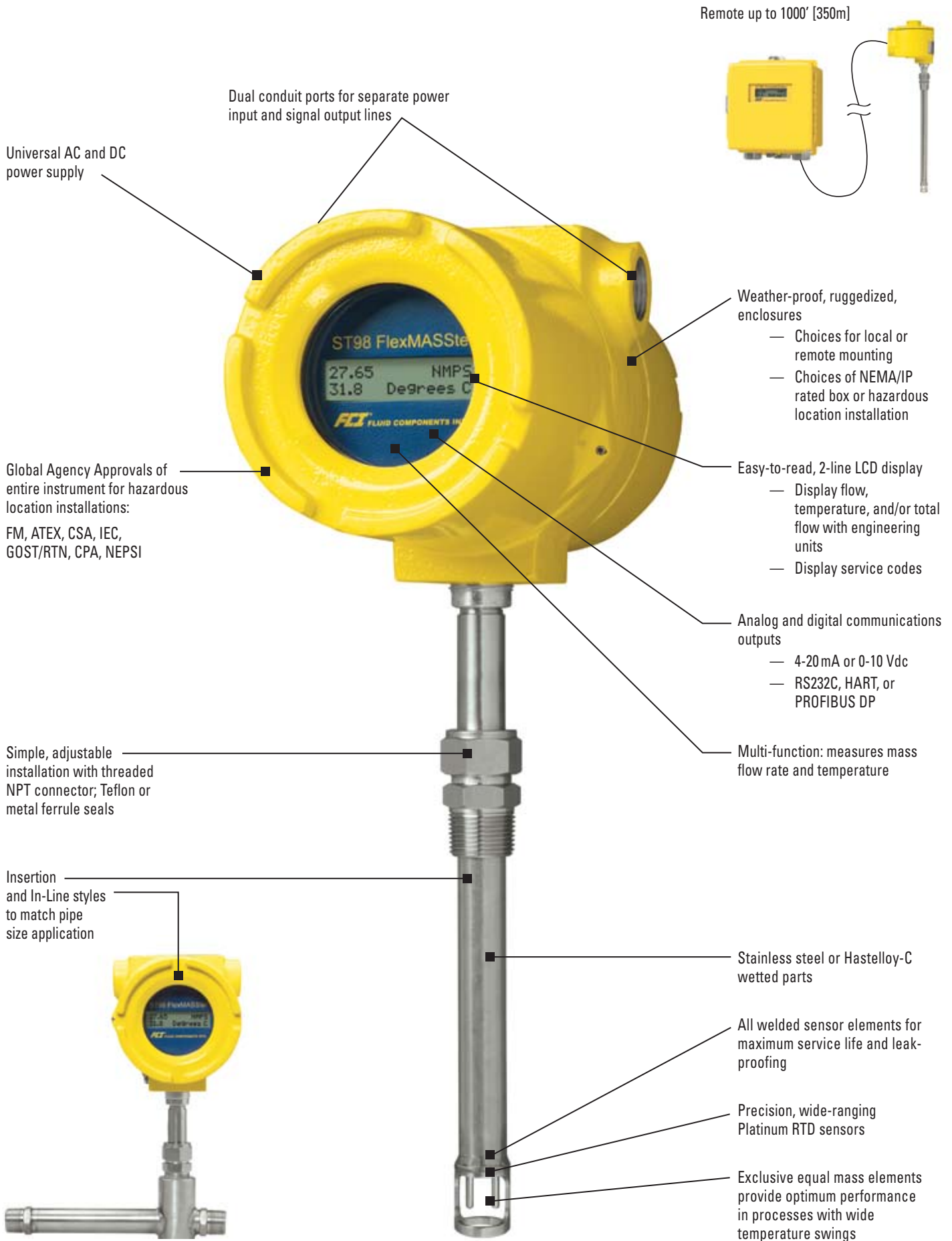

ST98 Series Mass Flow Meter General Specifications

Instrument

- **Flow Range**
ST98 Insertion Flow Element: 0.75 SFPS to 600 SFPS
[0.21 NMPS to 172 NMPS]
ST98L In-Line Flow Accessory: 0.0062 SCFM to 1850 SCFM
[0.01 Nm³/h to 3,140 Nm³/h]
– Air at standard conditions; 70 °F and 14.7 psia
[0 °C and 1013,25 bar (a)]
- **Media:** All gases that are compatible with the flow element material
- **Accuracy**
Flow: ±1% reading, 0.5% full scale standard accuracy
Temperature: ±2 °F [±2 °C] (display only, flow rate must be greater than 5 AFPS [1,5 m/sec])
Special higher accuracy calibration options available; contact FCI
- **Repeatability**
Flow: ±0.5% reading
Temperature: ±1 °F [±1 °C] (flow rate must be greater than 5 AFPS)
- **Temperature Coefficient**
With optional temperature compensation. Valid from 10% to 100% of full scale calibration.
Flow: Maximum ±0.015% of reading / °F up to 850 °F
[±0.03% of reading / °C up to 454 °C]
- **Turndown Ratio**
Standard: Factory set and field adjustable from 10:1 to 100:1 within calibrated flow range
- **Temperature Compensation**
Standard: ±30 °F [±16 °C]
Optional: ±100 °F [±55 °C]
- **Agency Approvals**
FM, ATEX, CSA, CRN, IEC, CPA, NEPSI, GOST/RTN, CE, PED (system approvals) †
- **Calibration:** Performed on NIST traceable equipment
- **MTBF (calculated):** 110 years

Flow Element

- **Material of Construction**
All-welded 316L stainless steel; Hastelloy-C optional
- **Operating Pressure**
Metal ferrule: 250 psig [17 bar (g)]
Teflon ferrule: 150 psig [10 bar (g)]
- **Operating Temperature (Process)**
ST98 Insertion Style:
–FP type element: -40 °F to 350 °F [-40 °C to 177 °C]
–S type element: -40 °F to 350 °F [-40 °C to 177 °C]
–S type (optional) element: -40 °F to 500 °F [-40 °C to 260 °C]
ST98HT Insertion Style (High Temperature Service): * †
–FP type element: -40 °F to 850 °F [-40 °C to 454 °C]
–S type element: -40 °F to 850 °F [-40 °C to 454 °C]
ST98L In-Line Style:
–F & –S type elements: -40 °F to 350 °F [-40 °C to 177 °C]

- **ST98 Insertion Flow Element**
Process Connection:
3/4" or 1" male NPT stainless steel compression fitting: adjustable Teflon ferrule; 150 psig [10 bar (g)] and 200 °F [93 °C] max., or metal ferrule; 250 psig [17 bar (g)] and 350 °F [177 °C] max.; thread-on flange optional; 1 1/4" male NPT or flanged retractable packing gland optional*
Insertion Length: Field adjustable lengths –
1" to 6" [25 to 152 mm]
1" to 12" [25 to 305 mm]
1" to 21" [25 to 533 mm]
Custom lengths optional*
- **ST98L In-Line Flow Tube**
Insertion flow element is threaded and keyed in an in-line flow tube, calibrated and supplied as a spool-piece; accessories include low flow injection tubes and built-in Vortab flow conditioners for optimum low flow rangeability and performance
Size: 1" diameter tubing; 1", 1 1/2" or 2" schedule 40 pipe
Length: 9 nominal diameters
Process Connection: Female NPT, male NPT, ANSI or DIN Flanges
Option: Flanges sized for flow tube
- **Remote Transmitter Configuration:** Transmitter may be mounted remotely from flow element using interconnecting cable (up to 1000 feet [350m])*

Flow Transmitter

- **Operating Temperature:** 0 °F to 140 °F [-18 ° to 60 °C]
- **Input Power:** 85 Vac to 265 Vac or 22 Vdc to 30 Vdc, 7 Watts maximum, 230 mA maximum
- **Outputs**
Analog: Single output selectable as 4-20 mA** (700 Ω max. load), 1-5 Vdc, 0-10 Vdc or 0-5 Vdc. (Vdc: 100K Ω min. load)
** *With fault indication per NAMUR, NE43 guideline: field selectable for high (≥21.6 mA) or low (≥3.75 mA) output signal is isolated from input power on AC Powered mode only)*
Digital: Standard: RS232C Serial I/O
Optional: HART, full two-way communications*; PROFIBUS, DP Profile 3 (Certification #Z01212)
Digital Display (optional): LCD, 2 line/16 character per line, indicating flow rate and process temperature and/or totalized flow

Other Options

- **Vortab Flow Conditioners:**
Model ST98L (in-line) can be provided and system calibrated with Vortab flow conditioners; refer to FCI+Vortab literature and contact FCI
- **Model FC88:** Hand-held, portable FCI flow meter field programmer; attach to ST98 I/O port for instrument set-up and trouble shooting
- * *Some configuration restrictions apply to ST98HT configured for 850 °F [454 °C] service. These include, but may not be limited to the following: Must select remote transmitter configuration. HART output is standard. Insertion element is fixed length with 1" male NPT or adjustable with selection of packing gland. Contact FCI for more information.*
- † *Agency approvals for 850 °F [454 °C] version pending. Contact FCI for current availability.*

Enclosures

Ordering Code Number	For Integral Configurations (Flow Meter/Transmitter Together)		
	A	1	B
Type	Carbon Steel Box	Aluminum Box	Aluminum Round
Temperature	0°F to 140°F [-18°C to 60°C]	0°F to 140°F [-18°C to 60°C]	0°F to 140°F [-18°C to 60°C]
Environmental Rating	NEMA 4, IP66	NEMA 4X, IP66	NEMA 4X, IP66
Installation Area Rating (System Approvals)	Nonincendive for Class I, Division 2, Groups A,B,C,D; Suitable for Class II, Division 2 Groups F, G; Class III, Division 2	Nonincendive for Class I, Division 2, Groups A,B,C,D; Suitable for Class II, Division 2 Groups F, G; Class III, Division 2	Class I, Division 1 Hazardous Locations: Groups B,C,D, E, F, G; ATEX / IECEx II2 GD Exd IIC T4

Ordering Code Number	For Remote Configurations * (Flow Meter Element Separated from Transmitter)				
	Element	Transmitter	Transmitter	Transmitter	Transmitter
Type	C, 2, D or E	C	2	D	E
Type	Aluminum	Carbon Steel Box	Aluminum Box	Aluminum Round	Panel Mount
Temperature	0°F to 140°F [-18°C to 60°C]	0°F to 140°F [-18°C to 60°C]	0°F to 140°F [-18°C to 60°C]	0°F to 140°F [-18°C to 60°C]	0°F to 140°F [-18°C to 60°C]
Environmental Rating	NEMA 4, IP67	NEMA 4, IP66	NEMA 4X, IP66	NEMA 4X, IP66	None
Installation Area Rating (System Approvals)	Class I, Division 1 Hazardous Locations: Groups B,C, D, E, F, G; ATEX / IECEx II2 GD Exd IIC T4	Nonincendive for Class I, Division 2, Groups A,B,C,D; Suitable for Class II, Division 2 Groups F, G; Class III, Division 2	Nonincendive for Class I, Division 2, Groups A,B,C,D; Suitable for Class II, Division 2 Groups F, G; Class III, Division 2	Class I, Division 1 Hazardous Locations: Groups B,C,D, E, F, G; ATEX / IECEx II2 GD Exd IIC T4	None

More Air / Gas Mass Flow Meter Solutions

In addition to the ST98 Series, FCI manufactures a broad line of thermal dispersion flow meter products for industrial and plant applications. From general-purpose air flow measurement to special-function, mixed gas flare flows; from small line sizes to the largest stacks and ducts, FCI has the selection to best solve your applications and ensure optimum solutions. Contact your local FCI representative or visit www.fluidcomponents.com for detailed product information and specifications on these products.



ST50

- **ST50** is a compact and economical, yet full featured meter designed for air, compressed air and nitrogen applications.

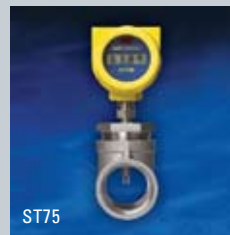

ST75

- **ST75** is a compact, in-line meter with extensive standard features that is the economical, easy-to specify alternative to other maintenance intensive flow technologies.

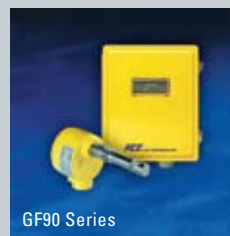

GF90 Series

- **GF90** and **GF92** offer an extensive feature suite and unique 3-gas calibration option that solves the toughest industry application requirements.



GF03

- **GF03** is specifically designed for flare flow metering and to meet the stringent environmental regulations that apply to this application.



MT86 / MT91 Series

- **MT86** and **MT91** "multi-point" flow measuring systems can be configured with two (2) to sixteen (16) flow sensing elements to optimize measurements within the largest of pipe and duct sizes.

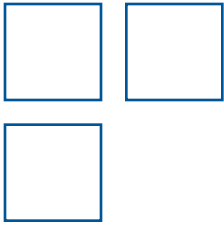

Model ST98 Insertion Flow Meter

Integral Transmitter

NEMA 4 Carbon Steel (Standard) or NEMA 4X, Aluminum

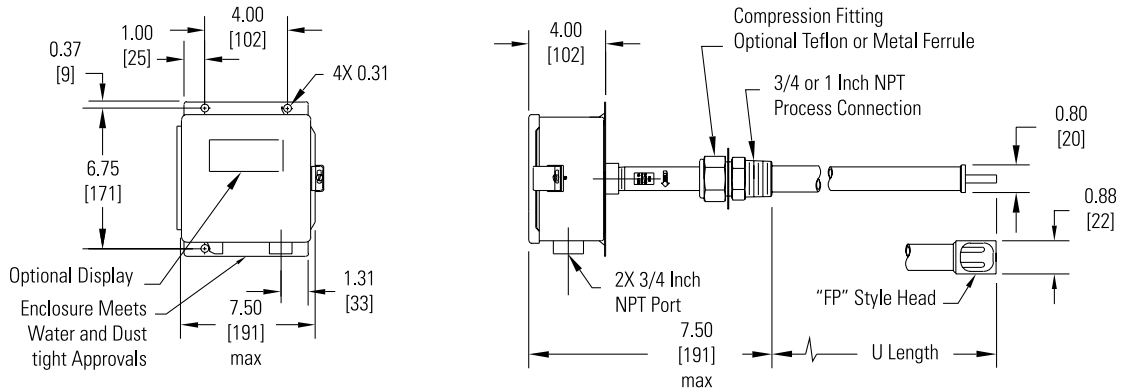

Hazardous Locations, Aluminum

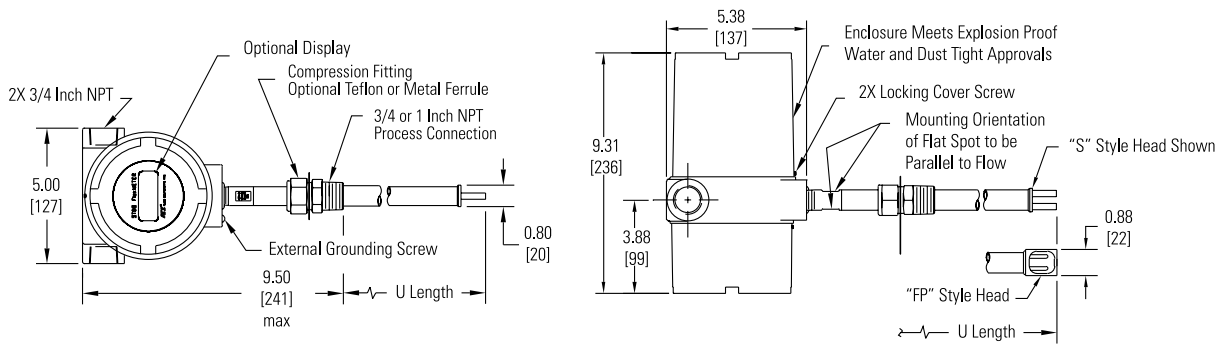

Remote Configuration

Flow Element: Hazardous Locations, Aluminum

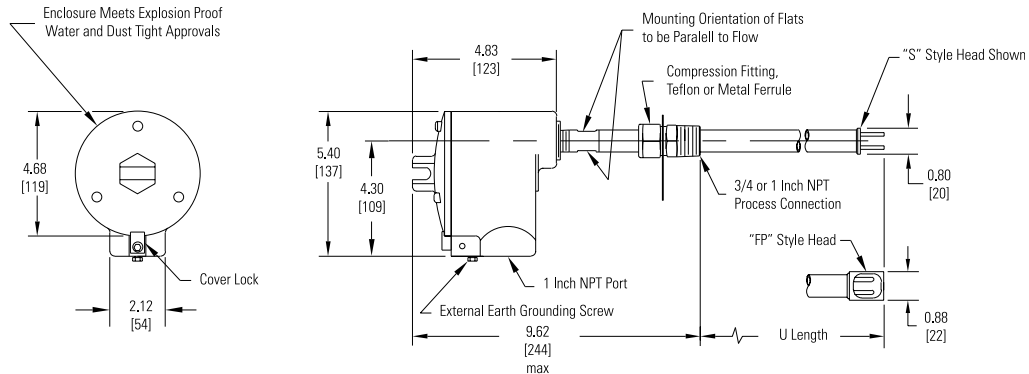

Enclosure: NEMA 4 Carbon Steel or NEMA 4X Aluminum

Enclosure: Hazardous Locations

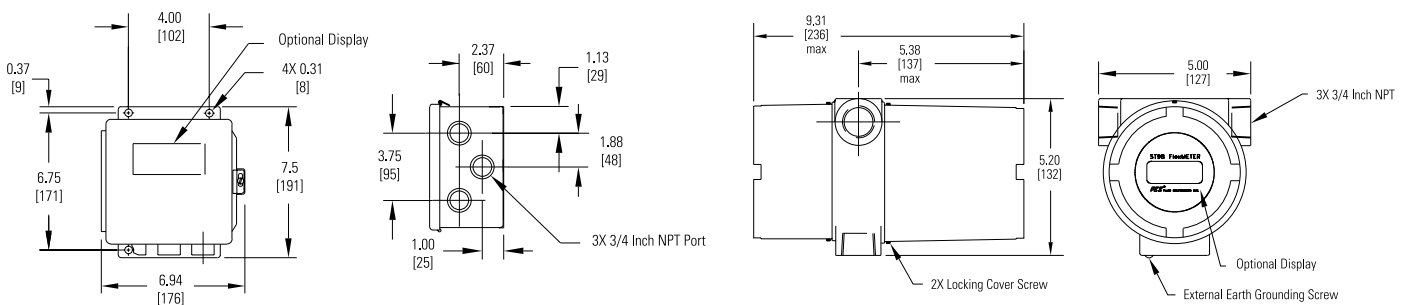

Model ST98L In-Line Flow Meter

Integral Transmitter

NEMA 4 Carbon Steel (Standard) or NEMA 4X, Aluminum

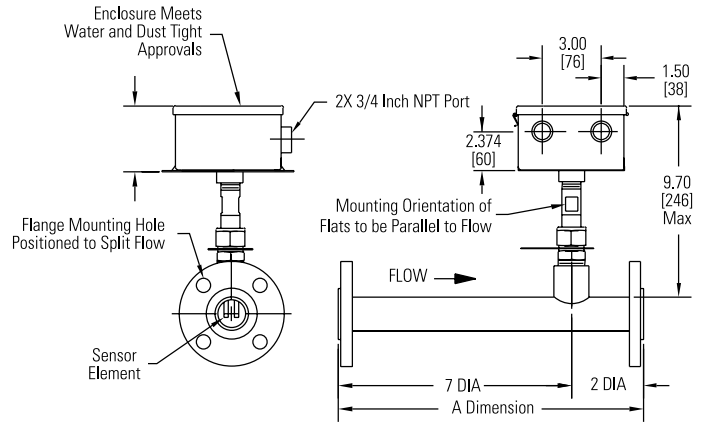
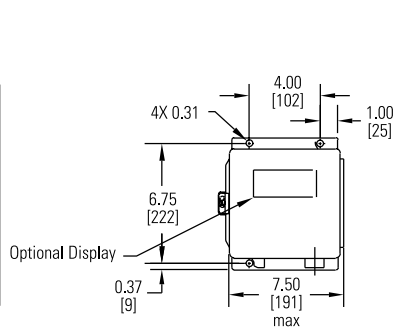
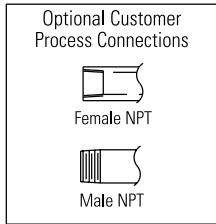

Hazardous Locations, Aluminum

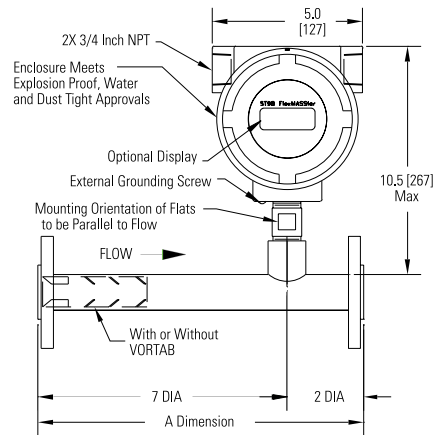
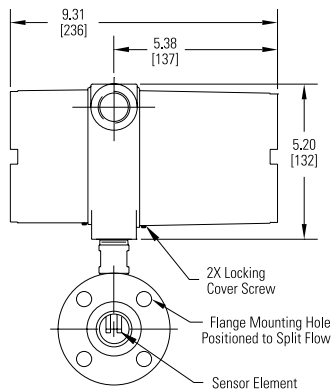

Note: Optional flange connections are shown for reference only. Standard process connection is male NPT.

Remote Configuration

Flow Element: Hazardous Locations, Aluminum
Transmitter: See Remote Configurations for ST98 Insertion Flowmeter

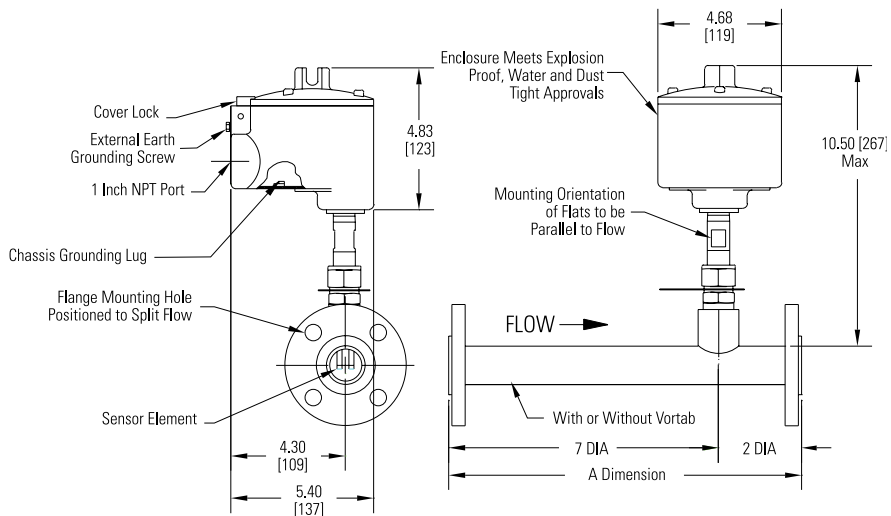

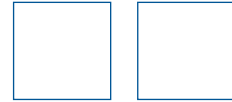
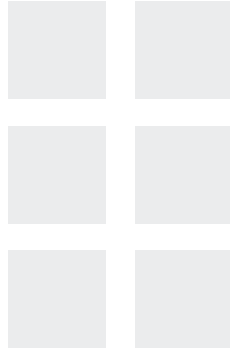

FCI FLUID COMPONENTS INTERNATIONAL LLC

Locally Represented By:

Visit FCI on the Worldwide Web: www.fluidcomponents.com

Headquarters: 1755 La Costa Meadows Drive
San Marcos, California 92078 USA

Phone: 760-744-6950 **Toll Free:** 800-854-1993 **Fax:** 760-736-6250

European Office: Persephonestraat 3-01 5047 TT Tilburg, The Netherlands
Phone: 31-13-5159989 **Fax:** 31-13-5799036

FCI is ISO 9001:2000 and AS9100 Certified